

HKS ELECTRONICS TECHNOLOGY

SLD T6

HKS SPEED LIMIT DEFENCER

INSTRUCTIONS



Pursuing the Ultimate in Engine Performance and Efficiency
HKS Company Limited

212290 – 047T
18th Oct 2000
Ver. 3-1. 02

Introduction

Thank you for purchasing the HKS SLD T6. Please read this information.

Part name	SLD (SPEED LIMIT DEFENCER) TYPE T6				
Use	Car speed limit system				
Vehicles fitted	Japanese models (DC 12V –ve earth vehicle only)				
Vehicle Model	Toyota Automatic	Car Name	Production year	Body type	Engine type
		Arist	'91.10 ~ '97.7	JZS147	2JZ-GTE
		Supra	'93. 5 ~ '97.7	JZA80	2JZ-GE
Code number					
Remarks	4502 - RT009				

HKS SLD T6. This part is for the speed limit on Toyota cars with automatic transmission. It removes the limit of 180 km/h. This part is for race track use only..

- You need these instructions. You must not cause danger to people or buildings
- If you need small any parts, please ask the shop where you purchased it or HKS' customer department. If you order repair parts, please ask for vehicle, body & engine type. If you can't find the vehicle details, use the part number
- Please understand, if another person uses this part and crashes, HKS take no responsibility
- Please use a specialist to fit this to your car. If you fit it and crash, this is not HKS' fault.
- If you fit to another type car, HKS are not responsible
- This part is only for DC 12V –ve earth Japanese built cars
- HKS sometimes change the design and instructions without prior notice
- Please don't use this outside of Japan

Contents

Safety	3
Parts List	4
Connector Fitting Instructions.....	5
Wiring Instructions	6
Fitting Guidelines	12
Post Installation Actions	12
Post Installation Check	12
Operation.....	13
Maintenance	13
Removal	13
Specification	13
Revision History.....	13

Safety

The following three boxes show the format for safety instruction.



Very Dangerous Liable to fatal injury or serious maiming



Warning Possible injury



Caution Could cause broken car or crash into building



Warning

- Keep this part clear of the driving position. It must not obstruct control of the vehicle
- This part is only DC 12V –ve earth. Do not fit to 24V system. If you fit to 24V system there may be a fire
- Before fitting this part, first remove the –ve battery terminal
- When you remove a connector, don't damage the connector or you could cause a fire
- After fitted and driving, if you get strange sounds or smells, stop immediately and consult the shop where you purchased it or HKS



Careful

- You must get a specialist to fit this part
- Fit it correctly. If you modify the vehicle this part may no longer work correctly and may cause electric shock or injury
- Please be careful. If you drop this part it may no longer function correctly
- Please protect against water and oil. If you fail to do this the part may no longer function correctly
- If you think the part is not functioning correctly, ask a specialist

- Daily check is your responsibility.
- This instruction is a basic explanation. If fitted to another type car, e.g. Crown, different fitting instructions are required.
- If you fit to your car or remove from your car, please read the user manual. If you don't have one, ask your car dealer
- If you fit this part to your car and you need to remove another part, please keep the parts
- Please keep all nuts and bolts when fitting. Don't over-tighten the nuts and bolts
- Please be careful with harness and wiring

Parts List

Before you fit to the car, please ensure you have all the parts



1	Main part	1
---	-----------	---

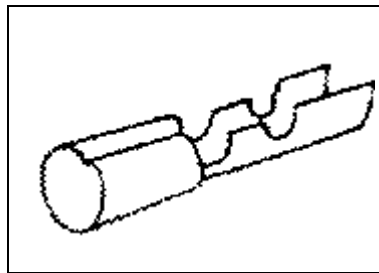

2	Female connector	7
---	------------------	---

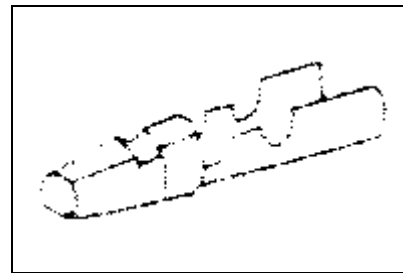

3	Male connector	7
---	----------------	---

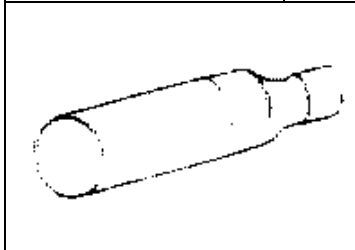

4	Female sleeve	7
---	---------------	---

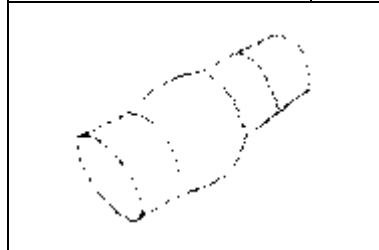

5	Male sleeve	7
---	-------------	---

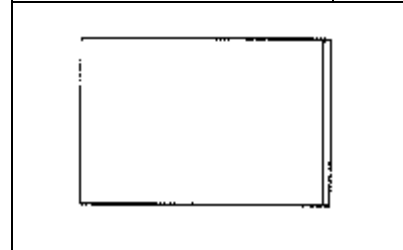

6	Double sided tape (50mm x 25mm)	1
---	------------------------------------	---

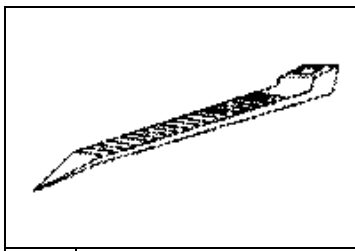

7	Cable tie (100mm)	4
---	-------------------	---

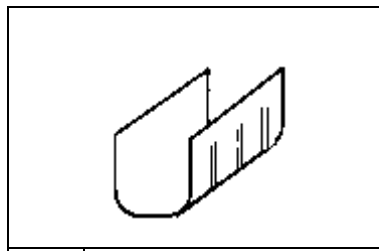

8	Splice	2
---	--------	---

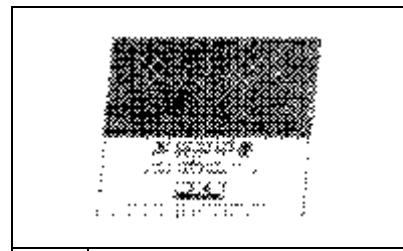

9	Instructions	1
---	--------------	---

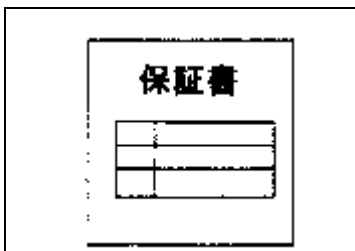

10	Agreement receipt	1
----	-------------------	---

- You must keep parts you don't use
- When you fit to the car you need:
 - Screwdriver
 - Cutters
 - 10mm Spanner
 - Socket wrench
 - Insulation tape

Connector Fitting Instructions

- Before fitting to the vehicle ensure the part is correct for your car. If you cannot understand please ask the shop where you purchased it or HKS company customer service.

1.1 Battery terminal

- (1) Remove -ve terminal of battery

2.1. How to fit male & female connectors

(1) Male connector

- (i) Cut insulation
- (ii) Remove insulation
- (iii) Push through sleeve
- (iv) Fit into male connector
- (v) Please make a good fit
- (vi) Using sleeve to insulate

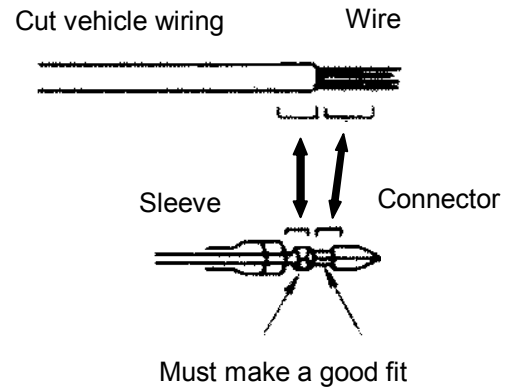

(2) Female connector

- (i) Cut insulation
- (ii) Remove insulation
- (iii) Push through sleeve
- (iv) Fit into female connector
- (v) Please make a good fit
- (vi) Use sleeve to insulate

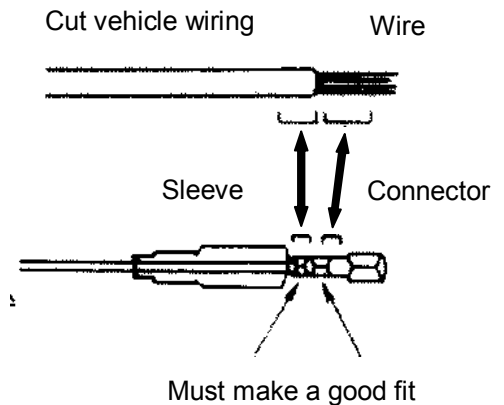

(3) How to fit the Splice

- (i) Remove about 5mm of the insulation
- (ii) Join to SLD wiring
- (iii) Use the splice to electrically join the wiring
- (iv) Ensure no short circuits by using insulation tape

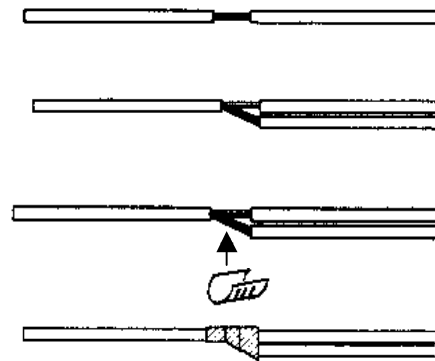

Advice

- When you need to crimp the connector and you don't have a special tool, you can use pliers or a soldering iron.
- You can make a stronger joint by folding the conductor before fitting the connector

2.2. Wiring schedule

On the JZS147 Arist NA, TRC is optional. If TRC is not fitted, just wire to the ECU. Please check whether your car has the TRC fitted.

If TRC (SLIP) is fitted please wire to both ECU and TRC

Car	Production year	Body Type	Engine Type	TRC (SLIP)	Diagram
Arist	'91.10 ~ '97.7	JZS147	2JZ-GTE	Fitted	A-ECU • A-TRC
			2JZ-GE	Fitted	
				Not fitted	B-ECU
Supra	'93.5 ~ '96.3	JZA80	2JZ-GTE (A/T)	Fitted	A-ECU • A-TCS
	'96.4 ~ '97.7			Fitted	A-ECU • B-TCS
	'93.5 ~ '97.7		2JZ-GE (A/T)	Not fitted	B-ECU

Wiring Instructions

Using the previous list, reference the wiring diagrams listed.

If TRC (SLIP) is not fitted to the car, it is only necessary to wire the ECU only. Please insulate the unused wires on the SLD.

ECU Wiring Access

- (1) Wrap the end of a screwdriver with insulating tape and prise open the clamp shown
- (2) Separate all the clips, and remove the passenger kick plate
- (3) After removing the passenger kick plate, roll back the carpet
- (4) To remove the dashboard computer cover panel, remove one bolt and one nut and one clip
- (5) The ECU wiring is under the dashboard computer cover.

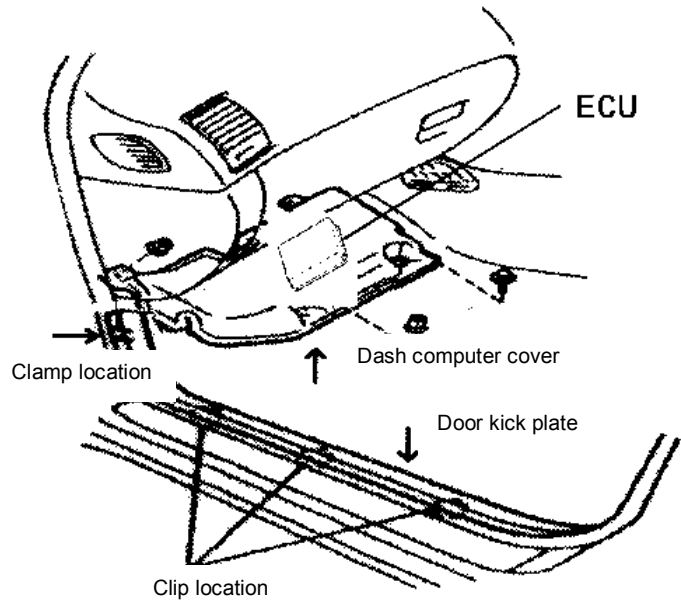

TRC Wiring Access

- (1) Remove installed panel under-cover behind the glove box in the passenger side. When done remove foot lamp
- (2) Hold glove box and remove retaining nut
- (3) Withdraw glove box slowly and separate the 2 connectors
- (4) After you have removed the glove box you can access the TRC computer

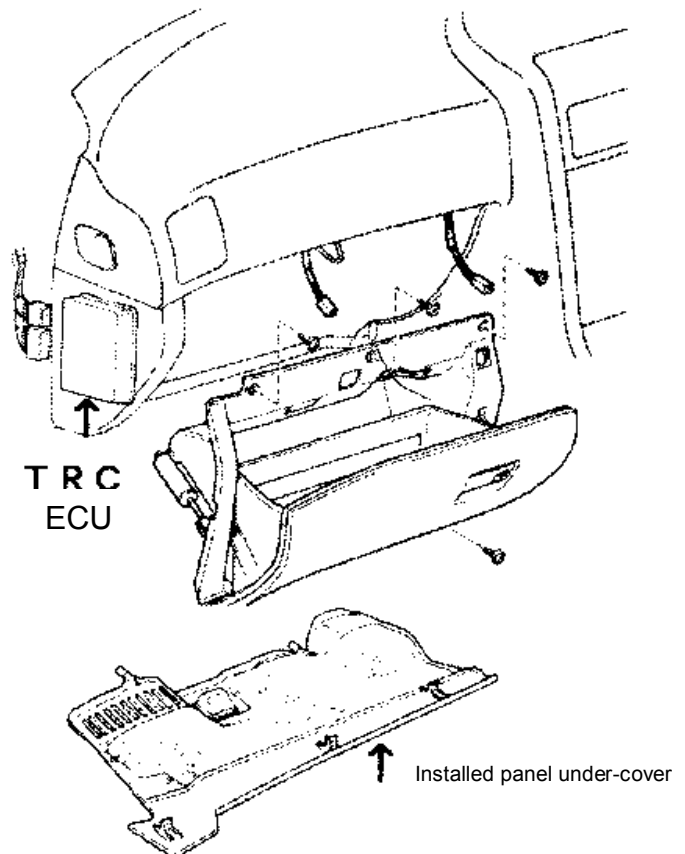

ECU & ETCS Wiring Access

- (1) Remove the door kick plate clips
- (2) Remove the door kick plate
- (3) Roll back the carpet
- (4) Remove the dashboard computer cover by removing 2 nuts
- (5) Expose wiring to ECU and ECTS computer

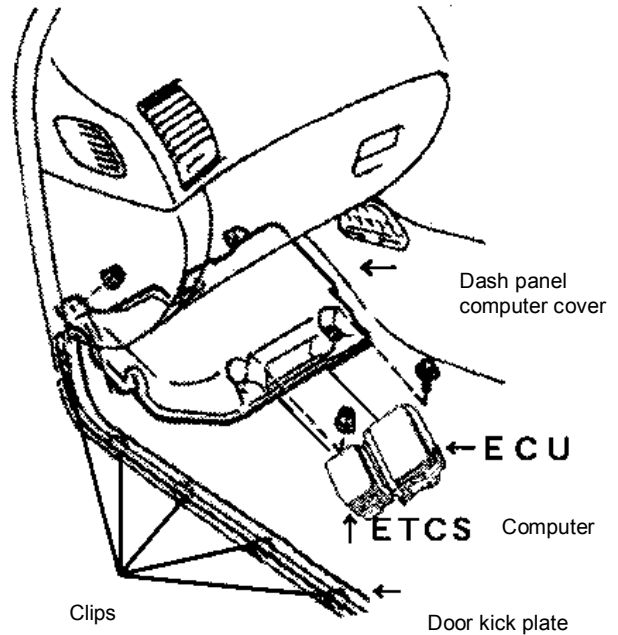

Explanation of symbols

- : Vehicle wiring side. Cut into wiring harness and fit male connector
- : Vehicle wiring side. Cut into wiring harness and fit female connector
- : Vehicle wiring side. Cut into wiring harness and fit splice
- : SLD female connector (already fitted to wiring)
- : SLD male connector (already fitted wiring)

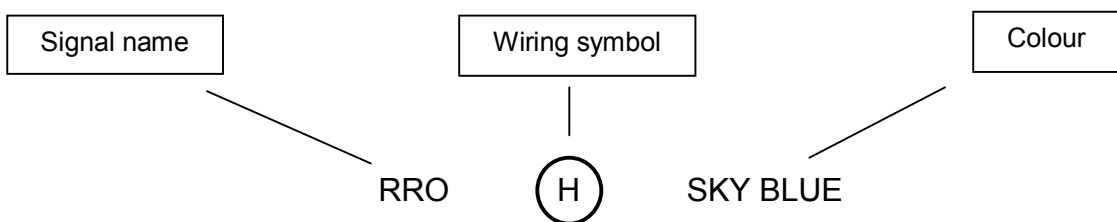

View of connector



Connector pin sequence from insert side

Picture

The following table refers to the SLD T6 signal wiring.

Signal name	Colour	Code	Meaning
Supply	Red	I	SLD T6 Power supply
Earth	Black	J	SLD T6 Earth
SPD	Yellow	S	Car speed signal output
	White	T	Car speed signal input
Solenoid	Orange	Q	Solenoid 2 output
	Green	R	Solenoid 2 input
FLO	Purple/Black	A	Left side front wheel speed sensor output
	Purple	B	Left side front wheel speed sensor input
FRO	Blue/Black	C	Right front wheel speed sensor output
	Blue	D	Right front wheel speed sensor input
RLO	Pink/Black	E	Rear left wheel speed sensor output
	Pink	F	Rear left wheel speed sensor input
RRO	Brown/Black	G	Rear right wheel speed sensor output
	Sky blue	H	Rear right wheel speed sensor input
SW	Yellow/Black	V	TRC (SLIP) OFF switch signal output
	Green/White	W	TRC (SLIP) OFF switch signal input

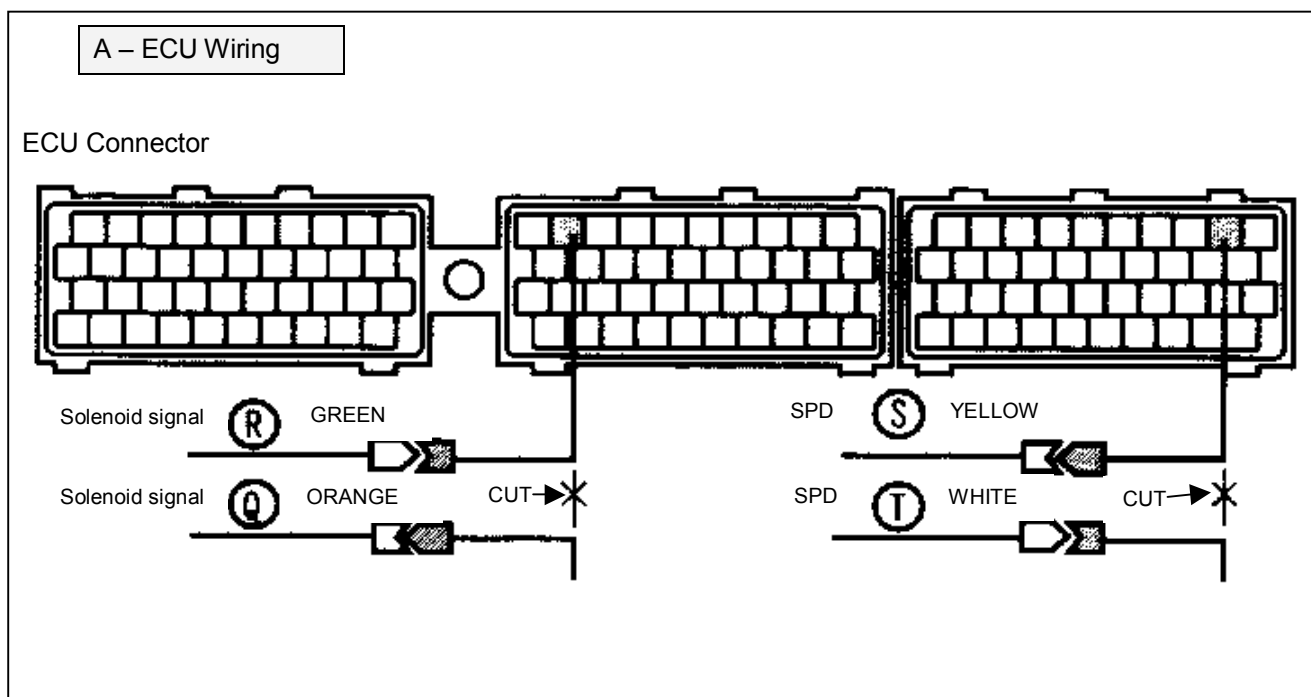

A – TRC Wiring

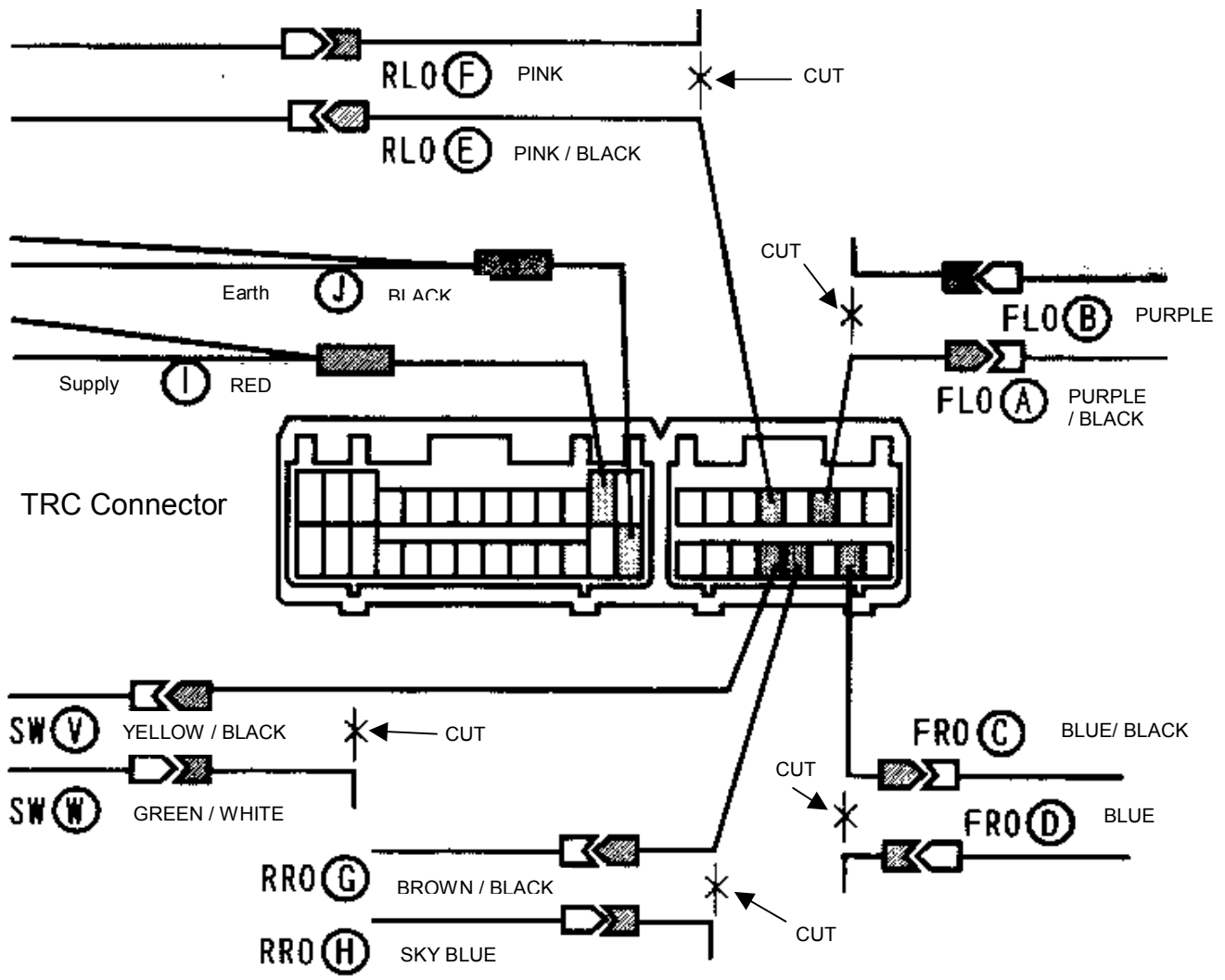

B – ECU Wiring

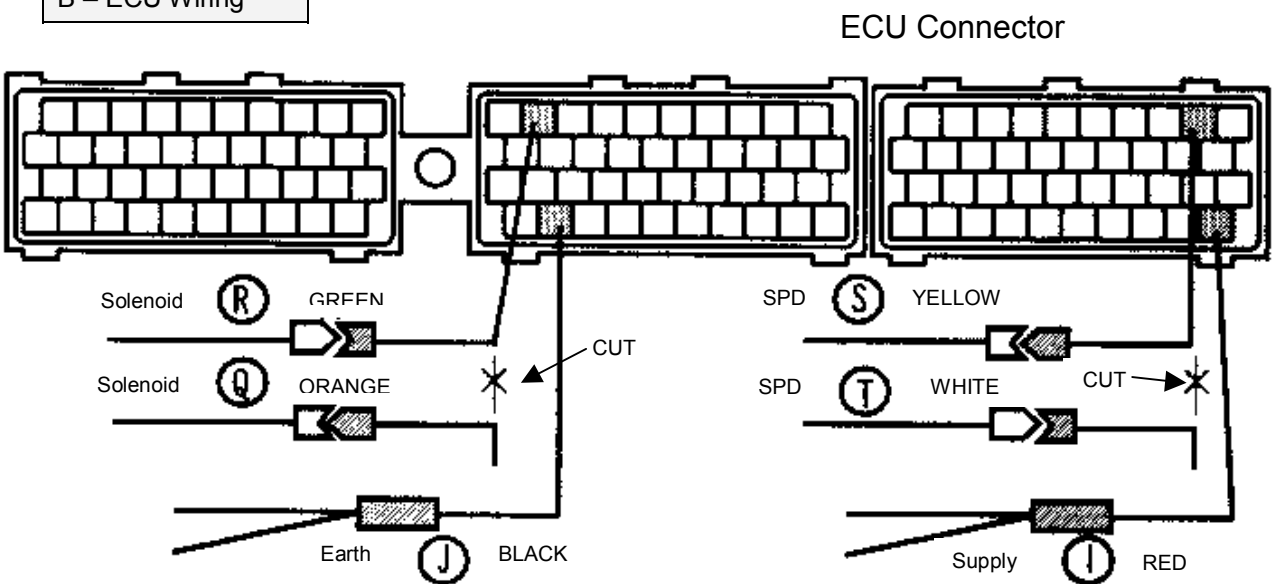

A – ETCS Wiring

ETCS Connector

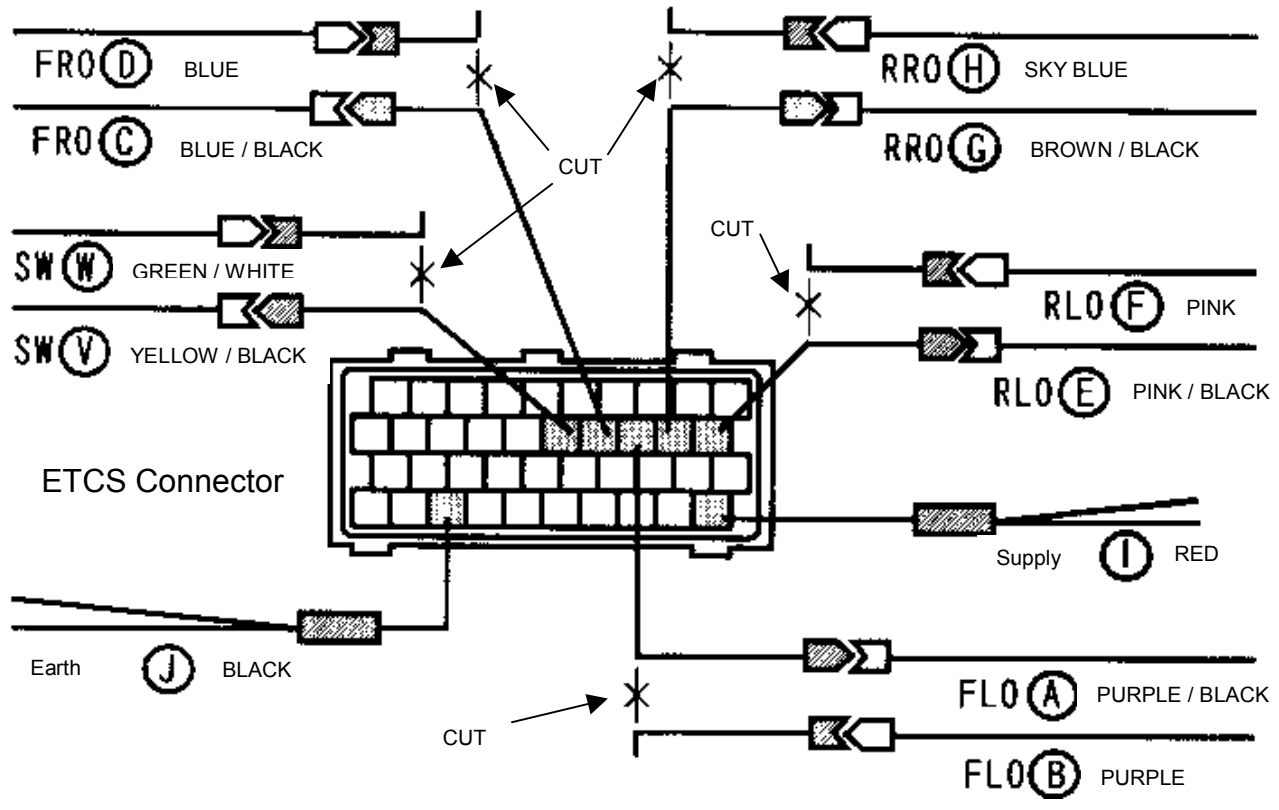

B – ETCS Wiring

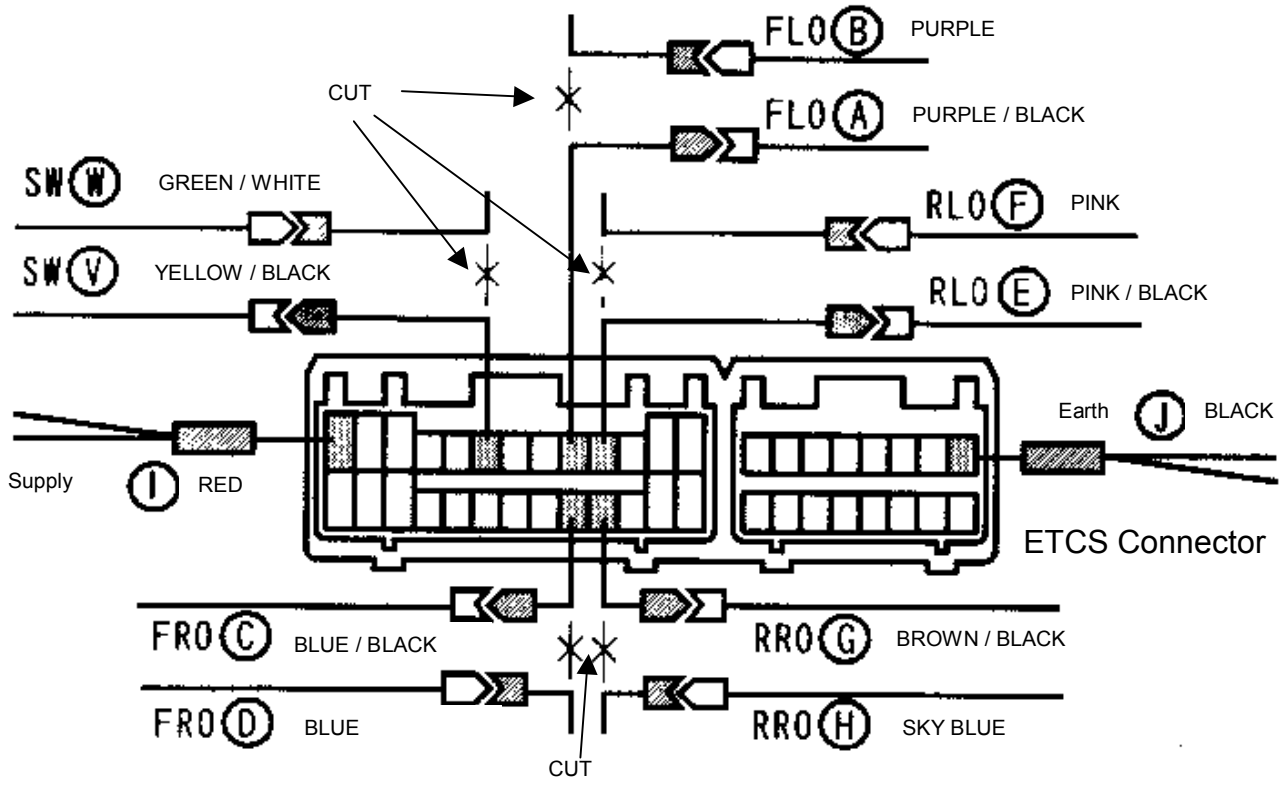

Fitting Guidelines

- (1) Please ensure that the wiring is correct and a good fit. It must not separate with gentle pressure
- (2) You must decide on the best location to fit the SLD T6
- (3) When you find a good place, you must remove the dust, water and oil using a neutral cleaner
- (4) You may use double sided tape to fit the SLD T6
- (5) You may use tie wrap to fit the SLD T6

Post Installation Actions

- (1) Replace all the parts and covers removed
- (2) Replace battery –ve battery terminal

Post Installation Check

When you fit these parts you must check the wiring

1. Before starting engine

Items to Confirm	Check
Wiring checks	
Ensure no short circuits	
Connectors are a good fit	
Battery –ve reconnected	

2. After engine on

Advice

Ensure the car is idling below 1000 RPM

Items to confirm	Check
Check for strange sounds, e.g. sound of arcing	
Harness is not too tight	
When engine turned off panels are not loose or rattling	

- When fitted by specialist
The check list must be given to the customer

Operation

SLD T6. If your car has TRC (SLIP) fitted it will not operate over 155 km/h. If you are over 155 km/h the dashboard lights TRC OFF and SLIP CONT OFF will be lit. Less than 150 km/h the slip control is in normal mode so the TRC OFF and SLIP CONT OFF lamps will be off. If slip control system is off the TRC OFF and SLIP CONT OFF lights will continue to be illuminated.

 **Warning**

- (1) You must be in high gear at speeds over 180 km/h. If you have SLD T6 you must be in OD. You must not remove the OD.
- (2) If you are driving quickly and you shift down you can possibly get engine braking
- (3) Please don't drive for long periods at speed in excess of 180km/h for reasons of transmission overheating
- (4) If you are doing in excess of 180 km/h and you suddenly shift to neutral, you may get engine braking.

Maintenance

- You must check every day
- Please don't handle the SLD T6 with dirty or oily hands
- If you need to clean the SLD T6 don't use solvent based cleaners

Removal

 **Warning**

- If you remove the unit you must tape the wires

Specification

- Voltage range..... DC10 ~ 16V
- Ambient temperature..... 0 ~ 70°C
- Maximum power consumption..... 2W

Revision History

Ver.	Year / Month	History of Change
3 – 1.01	2000 / 5	First issue
3 – 1.02	2000 / 10	Addition of wiring drawing